

# 496.3.703-2

## Vacuum cleaner motor performance

# DOMEL®

Vacuum cleaner motors with high efficiency 496.3.703-2/ 1100W/ 230V/ 50Hz are used for dry aspiration. Technical data and dimensions are given in the table. Vacuum cleaner motors consist of universal commutator motor and two fan stages. The rotor is supported with two ball bearings enabling vertical or horizontal installation of motor. The motor is designed for insulation class 155 (F) and constructed according to EN 60335-1.

### Technical data:

Normal operation:	$P_m$	$\geq$ 1000 W
Vacuum:	$P_{max}$	$\geq$ 25,5 kPa 102,5 in H <sub>2</sub> O
Air Flow:	$Q_{max}$	$\geq$ 65 dm <sup>3</sup> /s 138 CFM
Air Power:	$P_{2max}$	$\geq$ 520 W
Efficiency:	$\eta_{max}$	$\geq$ 40 %
Mass:	$m$	= 2,49 kg

Voltage:	230 V
Frequency:	50 Hz
Nominal Power:	1100 W

## Max power 1350W

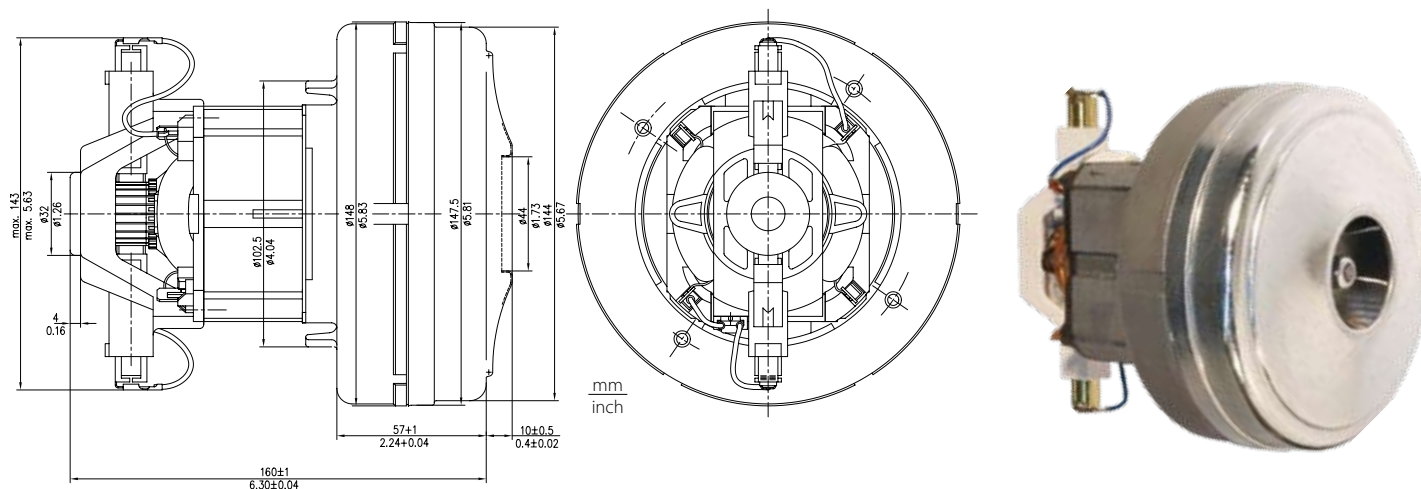

Dimensional and performance data are subject to change without notice.

Orifice		Current	Input Power	Speed	Pressure		Air Flow		Air power	Efficiency
mm	in*	A	W	min <sup>-1</sup>	kPa	in H <sub>2</sub> O	dm <sup>3</sup> /s	CFM	W	%
40	1 1/2	5,97	1320	24001	4,1	16,6	61,6	130,4	254	19,3
30	1 1/8	6,05	1337	23806	9,4	37,9	51,7	109,5	488	36,5
23	7/8	5,93	1311	24023	15,0	60,2	37,8	80,0	566	43,2
19	3/4	5,62	1247	24507	18,0	72,4	28,1	59,5	506	40,6
16	5/8	5,27	1174	25086	20,1	80,7	21,0	44,4	421	35,9
13	1/2	4,84	1081	26080	22,2	89,2	14,5	30,7	322	29,8
10	3/8	4,33	973	27381	23,8	95,5	8,9	18,9	211	21,7
6,5	1/4	3,84	869	28860	25,4	102,2	3,9	8,3	100	11,5
0	0	3,39	771	30732	26,8	107,6	0,0	0,0	0	0,0

Data above represent the performance of an average motor sample. Individual data may vary due to normal manufacturing variations.

\* Orifice in inch is only approximative.